

University of Technology

Department of Materials Engineering

General Materials Branch

Fourth Class

Casting Technology I

Lecture No 6: Sand Casting

Sand Casting

- Sand casting, also known as sand-mold casting, consists of pouring molten metal into a sand mold, allowing the metal to solidify, and then breaking up the mold to remove the casting. The casting must then be cleaned and



Sand Casting

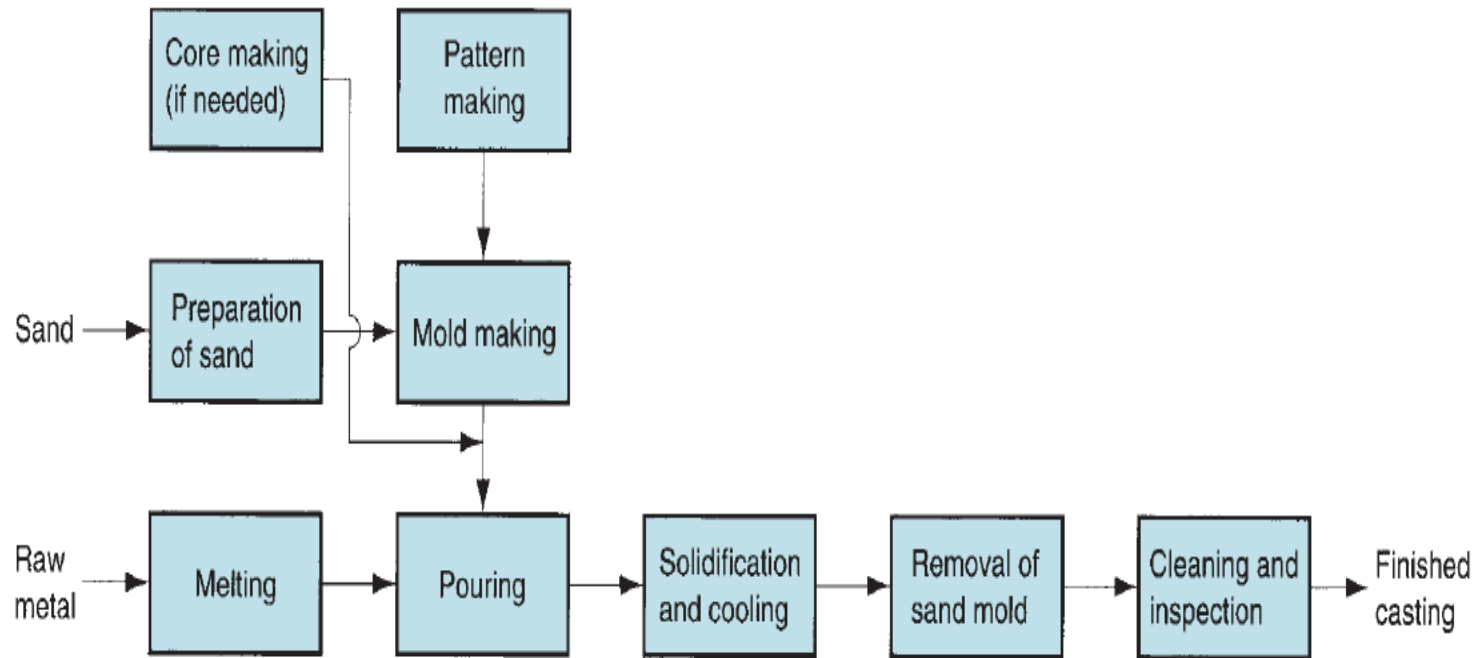
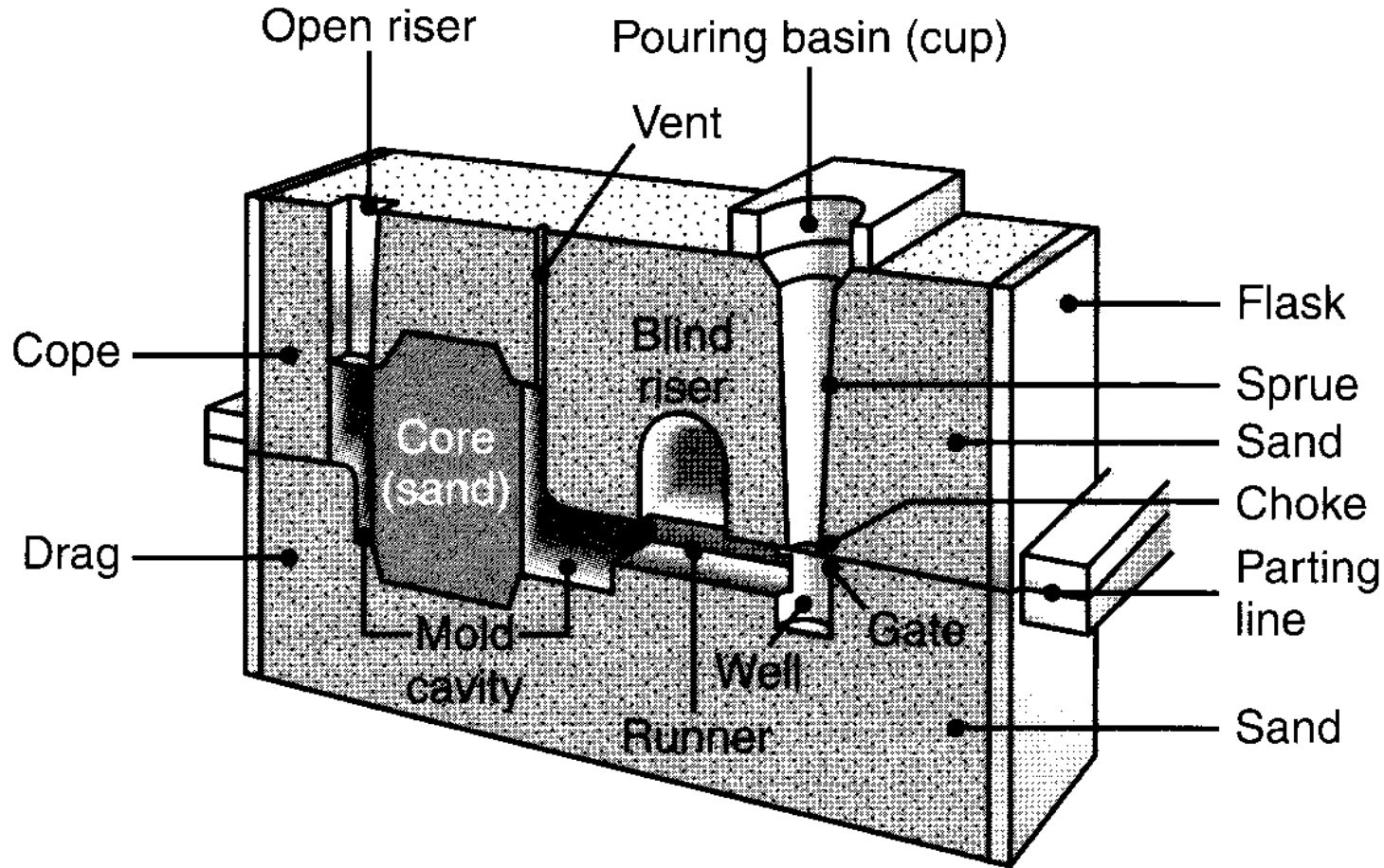

FIGURE 11.2 Steps in the production sequence in sand casting. The steps include not only the casting operation but also pattern making and mold making.

The major features of molds in sand casting

1. The flask, which supports the mold itself. Two-piece molds consist of a cope on top and a drag on the bottom; the seam between them is the parting line. When more than two pieces are used in a sand mold, the additional parts are called Cheeks.
2. A pouring basin or pouring cup, into which the molten metal is poured.
3. A sprue, through which the molten metal flows downward.
4. The runner system, which has channels that carry the molten metal from the sprue to the mold cavity. Gates are the inlets into the mold cavity.
5. Risers, which supply additional molten metal to the casting as it shrinks during solidification. Two types of risers-a blind riser and an open riser-are shown in Fig.
6. Cores, which are inserts made from sand. They are placed in the mold to form hollow regions or otherwise define the interior surface of the casting. Cores also are used on the outside of the casting to form features such as lettering on the surface or deep external pockets.

Sand Casting



Green Sand Casting

- Green-sand casting (where the term green implies that the mold material has not been fired or cured) is the most widely used process for casting both ferrous and nonferrous metals.
- The mold material is composed of sand blended with clay, water, and additives, and the molds fill by gravity feed.
- Tooling costs are low, and the entire process is one of the least expensive of the casting methods. Almost any metal can be cast, and there are few limits on the size, shape, weight, and complexity of the products. Over the years, green-sand casting has evolved from a manually intensive operation to a mechanized and automated system capable of producing over 300 molds per hour. As a result, it can be economically applied to both small and large production runs.



Green-Sand Casting

- **Process:** Sand, bonded with clay and water, is packed around a wood or metal pattern. The pattern is removed, and molten metal is poured into the cavity. When the metal has solidified, the mold is broken and the casting is removed.
- **Advantages:** Almost no limit on size, shape, weight, or complexity; low cost; almost any metal can be cast.
- **Limitations:** Tolerances and surface finish are poorer than in other casting processes; some machining is often required; relatively slow production rate; a parting line and draft are needed to facilitate pattern removal; due to sprues, gates, and risers, typical yields range from 50% to 85%.
- **Common metals:** Cast iron, steel, stainless steel, and casting alloys of aluminum, copper, magnesium, and nickel.
- **Size limits:** 30 g to 3000 kg (1 oz to 6000 lb).
- **Thickness limits:** As thin as 0.25 cm (in.), with no maximum.
- **Typical tolerances:** 0.8 mm for first 15 cm (in. for first 6 in.), 0.003 cm for each additional cm; additional increment for dimensions across the parting line
- **Draft allowances:** 1–3°.
- **Surface finish:** 2.5–25 microns (100–1000 μ in.) rms.

THE MAKING OF SAND MOLDS



Jolting

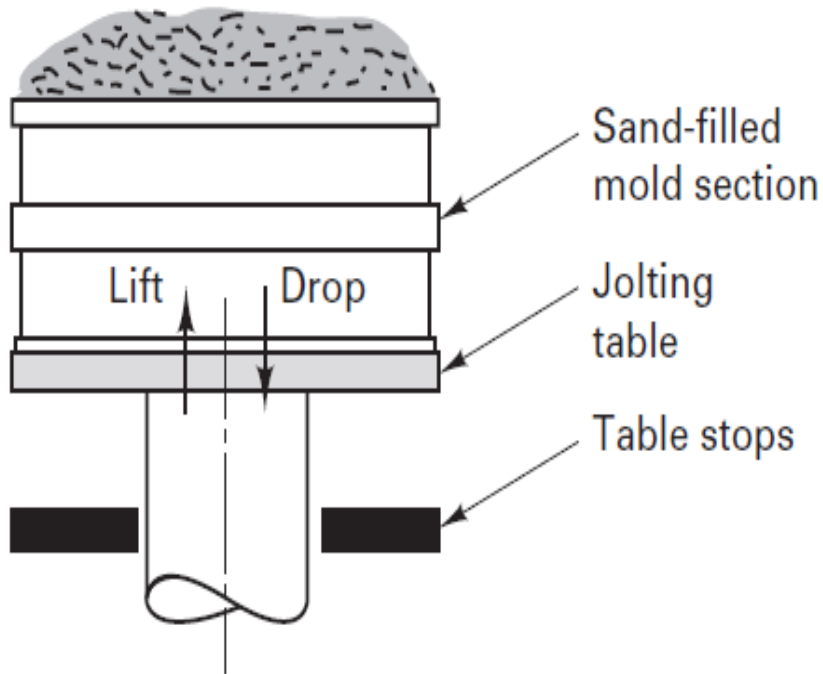

FIGURE 12-12 Jolting a mold section.
(Note: The pattern is on the bottom, where the greatest packing is expected.)

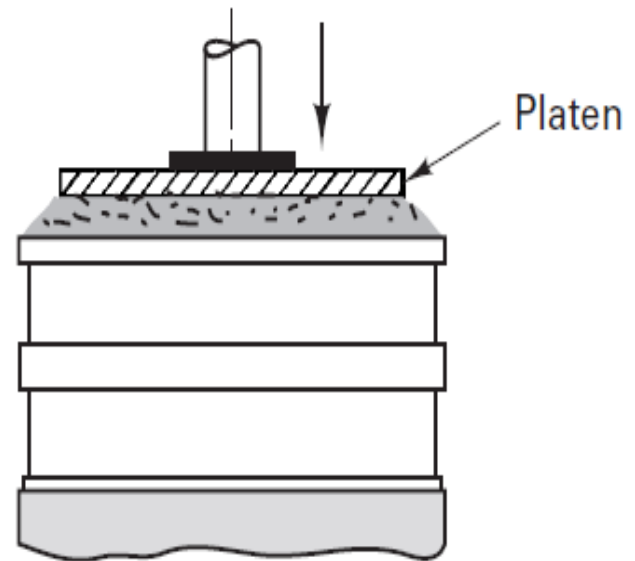
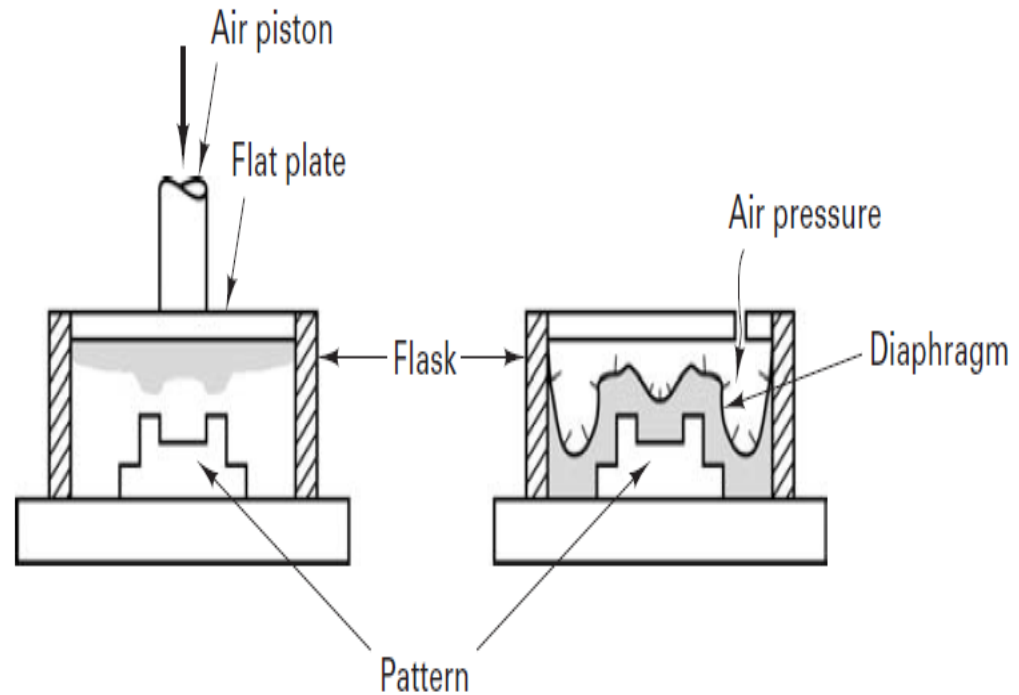

FIGURE 12-13 Squeezing a sand-filled mold section. While the pattern is on the bottom, the highest packing will be directly under the squeeze head.

Squeezing

FIGURE 12-14 Schematic diagram showing relative sand densities obtained by flat-plate squeezing, where all areas get vertically compressed by the same amount of movement (left) and by flexible-diaphragm squeezing, where all areas flow to the same resisting pressure (right).



Automatic match-plate molding

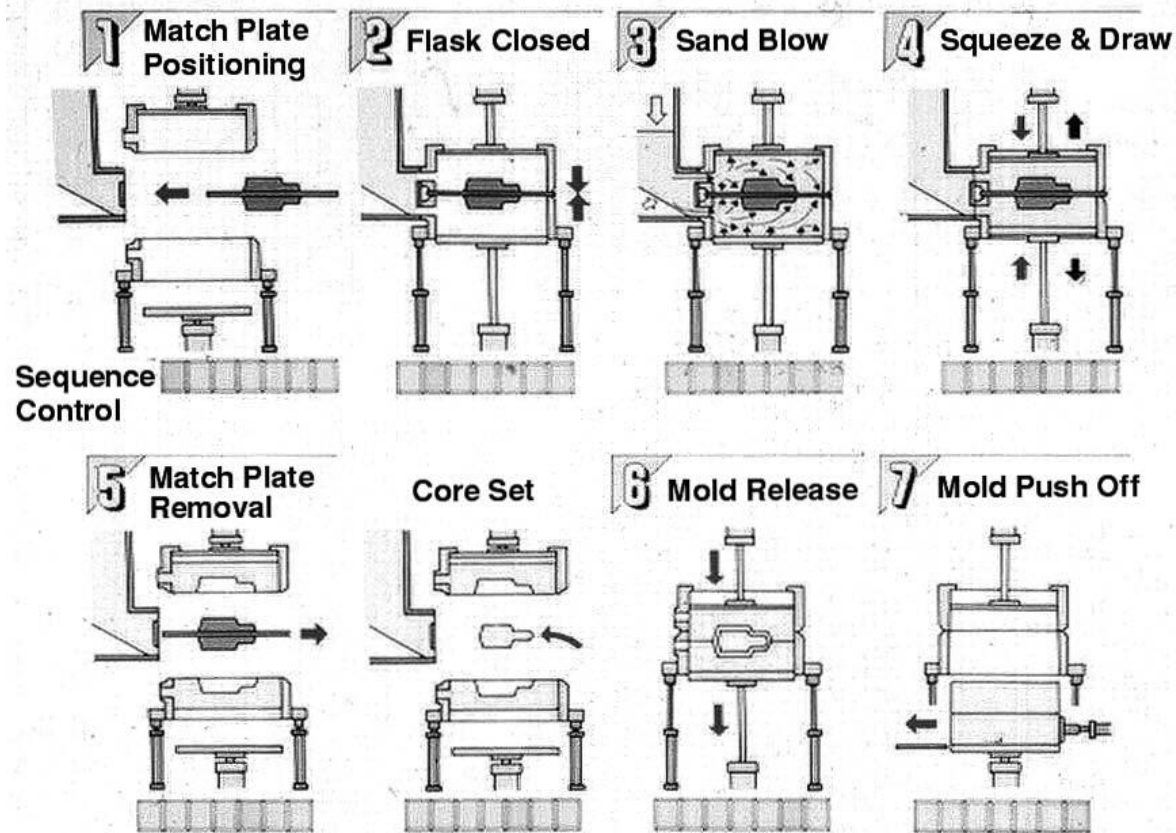

Vertically parted Flaskless molding

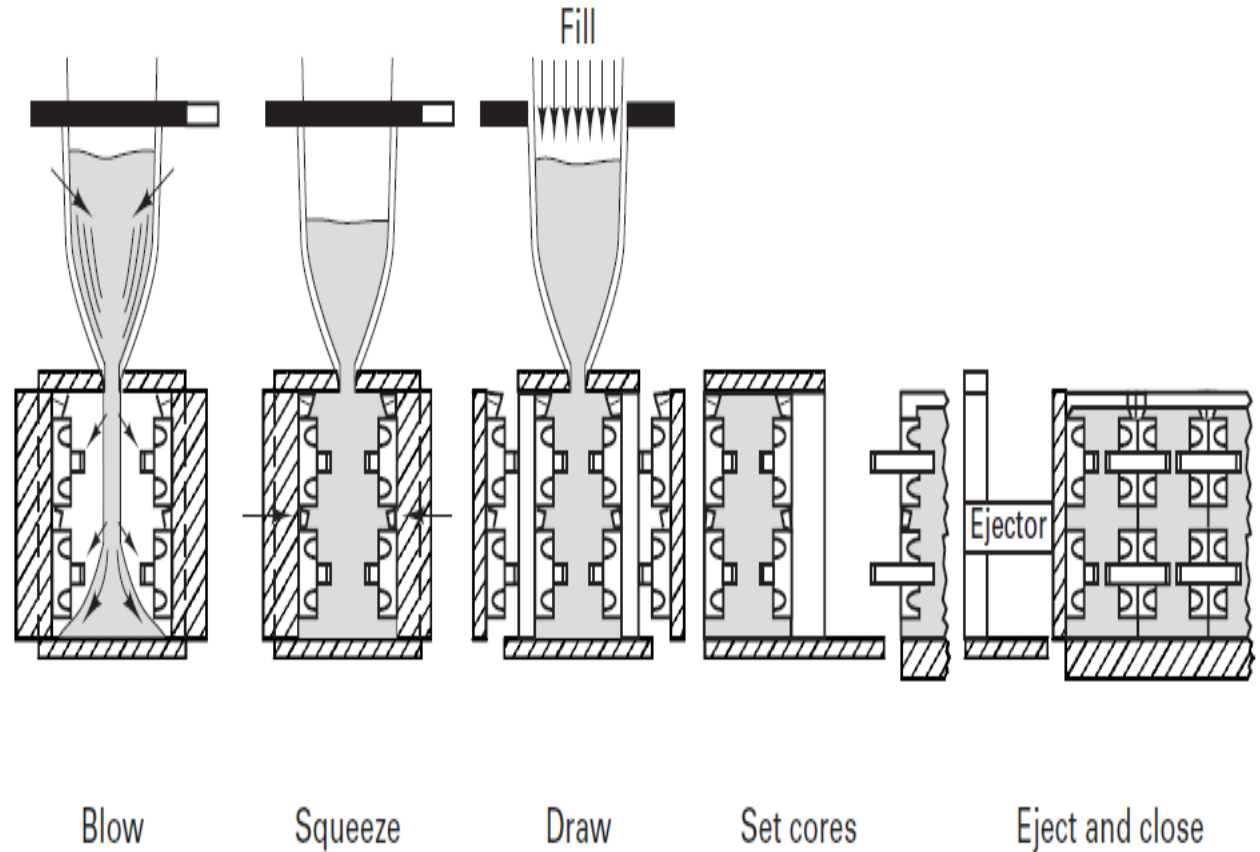

FIGURE 12-16 Vertically parted flaskless molding with inset cores. Note how one mold block now contains both the cope-and-drag impressions.